

Juraj Kojs

The Wetland

for cello and electronics

Dedicated to Madeleine Shapiro

The tempest
and the splashes
after mist settled
under the leaves
the wet games began
that autumn
startling warm pebbles.

Duration: ca. 14'30"

©2010

Technical set up:

- 1 Apple computer running MAX 5
- 1 stereo audio set up
- 1 microphone, close cello miking preferred
- 1 stereo audio interface

The accompanying electronics will be provided upon request.

Blending: The acoustic (amplified) cello should be heard pronouncedly throughout.

Durations of individual movements are approximate. If at all, a stopwatch can be used for orientation. The patch operator follows the cellist throughout the performance, enabling the maximal musical flow.

In movement 6, the cellist may cover his/her fingers with aluminum foil or use the garden gloves.

The Wetland was premiered by Madeleine Shapiro at Harold Golen Gallery in Miami, FL on September 22, 2010.

Legend for *And The Splashes, Under the Leaves, That Autumn* and *Startling Warm Pebbles*.

Body parts:

Odd numbers: perform with your right hand (RH).

Even numbers: perform with your left hand (LH).

Perform with thumbs: 3 and 4

Perform with a group of

fingers: the rest

1, 2: on the side of the fingerboard

3, 4: on strings over the fingerboard (3= C, G and 4= D, A)

5, 6: on strings between the fingerboard and bridge

7, 8: on the bridge

9, 10: on the side of the bridge

11, 12: on the strings behind the bridge
(closer to the bridge)

13, 14: on the strings behind the bridge
(closer to the tail)

15, 16: on the screws

17, 18: on the tail

19, 20: on the front bout

21, 22: on the side of the instrument

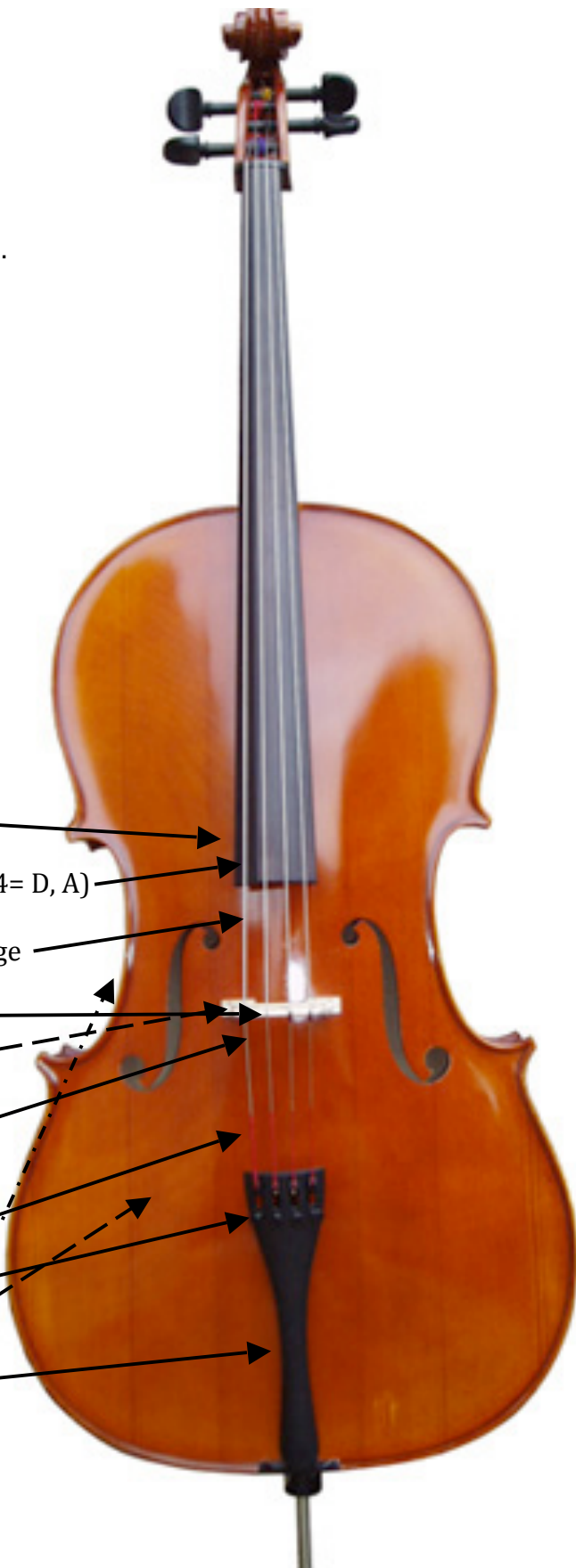

Electronics: 1. *The Tempest* (1'20").
Cue 1

Bow on any string(s) slowly with full force. Produce continuous intense scratch tone.

0" Thunder Intro
20" On stopped D and A strings. ca. 40"

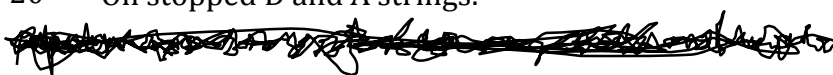

Slow down. Introduce stops and crackling, pulling the bow up the strings. Remain on strings when stopped.

ca. 55"

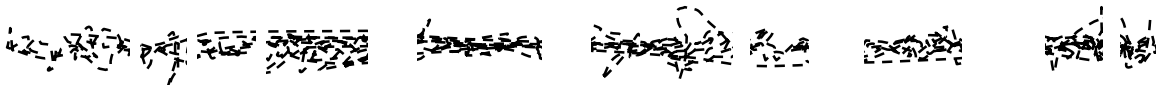

Rhythmisize. Crackling and scratch tone. Keep adding longer pauses. Travel small distances on the string.

ca. 1'10"

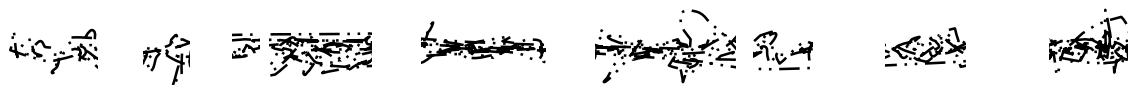

Sparse violent gestures: seldom thunders. Freeze in between.

ca. 1'20"



*Pause.
(Electronics
continue for ca.
20".)*

Electronics: 2. *And the Splashes* (ca. 3').

Cue 2

Legend: Pizz. 13: C = pluck the C string behind the bridge closer to the tail.

C—A, A—C: strum-pluck through all strings in the given direction with palms.

↗: perform the next gesture immediately.

~~: light muting with fingertips (f.tip) or nails, producing a buzzing slowly decaying resonance.

l.v.: let vibrate

x: stop (mute) the resonating string or hit and mute the stopped string.

x- : mute and hold strings

~x: pluck and mute right away.

Duration of rests: begin counting immediately after finishing performing the previous gesture.

Rest : ca. 5" $\left[\begin{matrix} 8 & 8 \\ 7, 7, 7, 7 \end{matrix} \right]_{19}^{20}$ Rest: ca. 4"

LH (left hand)	20: Irregular tapping	3"	Tap	20 20	1"	20: Irregular tapping	ca. 10"
RH (right hand)	Pizz. 13: C		19 19	Tap		Pizz. 13: C, G	2"

LH	Pizz. 14:A	3"	14:A	3"	A	2"	C	5"	Pluck 20 20	4"	A-C	3"
RH	13: C, G		13: C, G						Pluck 19 19		Pizz. 13: A-C	simile

with inner knuckles

LH	14:C-A	3"	12:C-A	3"	12 10	3"	10	2"	2"	3"	
RH	11:A-C		11:A-C	9:A-C	13 11	simile	YES: pluck the bridge.			3:C~~	f.tip

LH		2"		3"	4:G~~	2"		3"	G~~	3"	G~~	3"
RH	3:C~~	nail	C~~	C~~	f.tip	nail	C~~	nail	f.tip	G~~	f.tip	

LH	G~~	4"	G~~	3"	G~~	3"	A~~	3"	A~~	2"	D~~	2"	A~~ G~~	1"
RH	G~~	nail	C~~	f.tip	C~~	nail	C~~	f.tip	C~~	f.tip	G~~	f.tip	D~~ D~~	l.v.

LH	A~~	A-C:	G~~x	3"	G~~x	2"	A-C:	4"	with inner knuckles	C-A	3"	C-A:	4"
RH	D~~	C~~	C~~	f.tip	C~~		A-C	with inner knuckles	A-C	simile	A-C	A-C	

LH	C-A:	4"	C-A:	4"	C-A:	20: hit	3"	C-A:	3"		
RH	A-C	simile	A-C C-A	simile	C-A A-C	19: hit	C-A	nail	1" 5,6: C-A	1" 13,14: C-A	nail

LH	C-A:	3"	C-A:	3"	10	1"	10	3"	simile 22	3"	22	3"	22	4"
RH	13,14: C-A	nail	Combined: 5, 6, 7, 8, 11, 12: C-A	nail	Combined: 5, 6, 7, 8, 11, 12: C-A	nail	Pluck the f-hole	1 f.tip	simile	11 21	21	21	21	

Pause. (Electronics continue for ca. 5'.)

Electronics: 3. *After Mist Settled* (1'10").
 Cue 3

Bridge  ca. 30"
 Increase pressure.....

Bridge  ca. 15"
 Allow occasional slips and squeaks.
 Light.....Increase pressure.....Light.....Increase pressure suddenly

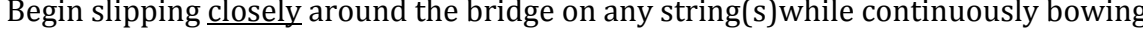
behind  ca. 15"
 Bridge front
 Begin slipping closely around the bridge on any string(s) while continuously bowing.
 Light.....Decrease pressure.....Heavy.....Decrease pressure suddenly







behind  ca. 10"
 Bridge front
Bow in the air.....Light pressure.....Air.....Put the bow down.

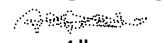
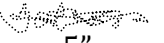
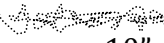
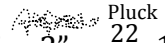
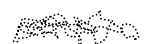
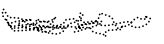
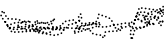
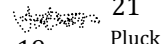

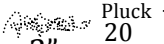
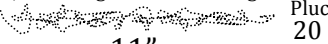
*Pause.
 (Electronics continue for ca. 10".)*

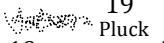
Electronics: 4. *Under the Leaves* (ca. 1'20").
 Cue 4

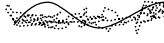
Respect the full duration of rests.

	20: tap with f.tips		20: tap with f.tips		20: simile		20:
LH	 4" Pluck 22	3"	 5" Pluck 22	3"	 10" Pluck 22	2"	 2" Pluck 22
RH	 21 Pluck		 21 Pluck		 21 Pluck		 21 Pluck
	19: tap with f.tips		19: tap with f.tips		19: simile		19:
	<i>ppp</i>		<i>pp</i>		<i>mf</i>		<i>f</i>
					up and down		

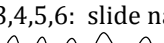
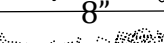
	20:	3,4 and higher on the strings:	20:	20:	3,4,5,6: nails
LH	 2" Pluck 20	 11" Pluck 20	3"	 10" Pluck 20	4"  9" 4"
RH	 19 Pluck	 5,6: Pluck 19		 19: with nails	 3,4,5,6: with nails
	19: <i>ff</i>	5,6: <i>ppp</i> ----- <i>fff</i>		Increase density and dynamics.	Up and down. Fast speed.





	3,4,5,6: slide nails	Keep sliding and	20: simile
LH	 8" Pluck 22	<i>tremolo ad. lib</i>	f.tips-----nails
RH	 5,11: f.tips	 7" Pluck 21	 6" Pluck 21
	Fast tremolo	tremolo with f.tips.	19: simile
		anywhere on the strings. Keep changing positions.	f-----fff
			f.tips-----nails

*Pause.
 (Electronics continue for ca. 5".)*

Electronics:
Cue 5

5. *The Wet Games Began* (ca. 2').
Perform circular movements.

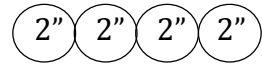
LH _____ 5" _____ 5" _____ 4" _____ 4" _____ 5" _____ 3"

RH      









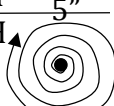
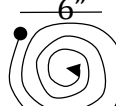

5: C
with flat palms
and flat fingers
round motion, no
attack









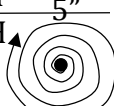
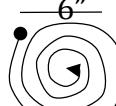

5: C, G
simile

5,7:
all strings

5,7 5,7,11 5,7,11,13
simile

3,5,7

LH            

RH            

5,7,11

11,7,5,3
end on 7

3

19

















7

















3

7

13

5

LH                 

RH                 

3

5,7,11

5

















11,13

















(0.5")

3

3

4"

LH                 

RH                 

pluck
4: C—A
with palms

Add weight
>
x

5"

pluck
5: A—C
with palms

pluck
4: C—A
with palms

Add weight
>
x

5"

pluck
5: A—C
with palms

pluck
4: C—A
with palms

Add weight
>
x

5"

pluck
5: A—C
with palms

pluck
4: C—A
with palms

Add weight
>
x

5"

5"

Pause.
(Electronics
continue for
ca. 20".)

Electronics: 6. *That Autumn* (ca. 2'15").
Cue 6

Legend: Body parts: See page 2.

Odd numbers: perform with your right hand (RH).

Even numbers: perform with your left hand (LH).

Perform with thumbs: 3 and 4

Perform with a group of
fingers: the rest

Cover the fingers with aluminum foil to achieve further percussiveness. Garden gloves can be also used.

Tap lightly with your fingers in a chaotic manner on the strings around the bridge.
Prepare to flow smoothly to the rhythmic patterns.



Tap the following rhythms with fingers and thumbs in *fast* pace with steady acceleration. Produce regular pulse, quasi *perpetuum mobile*.

3x [9, 10, 3, 4]

3x [9, 10, 3, 4, 7, 10, 3, 4] 4x [9, 10, 3, 4, 7, 8, 3, 4] 4x [9, 3, 4, 10] 3x [3, 4, 4]

4x [9, 3, 4, 10] [9, 10, 9] [9, 10, 9] [9, 10, 9] 2x [9, 3, 4, 9, 10, 4, 3, 9]

2x [9, 9, 3, 4, 10, 10, 4, 3] 4x [9, 3, 4, 10, 9, 3, 9] 3x [3, 4, 3] 3x $\begin{pmatrix} 10 \\ 9, 3, 4, 10, 9, 3, 9 \end{pmatrix}$

3x $\begin{pmatrix} 4, 6, 4 \\ 3, 5, 3 \end{pmatrix}$ 2x $\begin{matrix} > \\ 9, 10, 3, 4, 9, 3, 10, 9, 4, 3, 10, 4 \end{matrix}$ 3x $\begin{pmatrix} 4, 8 \\ 3, 9 \end{pmatrix}$

2x $\begin{matrix} > \\ 9, 3, 4, 10, 9, 9, 10, 3, 4, 5, 6, 3, 4, 5, 6, 3, 4 \end{matrix}$

3x [11, 11, 6, 5, 11, 12, 5, 11, 6, 12, 5, 11, 6, 12, 5]

4x $\begin{pmatrix} 8 & & 8 & & 8 & & 8 & & 8 & & 8 & & 6 & 6 \\ 13, 13, 13, 13, 13, 13, 13, 15, 13, 15 \end{pmatrix}$ 3x $\begin{pmatrix} 8 & & 8 & & 8 & & 8 & & 8 & & 6 & 6 \\ 15, 15, 15, 15, 15, 15, 15, 15, 15, 15, 15, 17, 17 \end{pmatrix}$

2x $\begin{pmatrix} 8 & 8 \\ 7, 7, 7, 7 \end{pmatrix}$ $\begin{matrix} 20 \\ 19 \end{matrix}$ 2x $\begin{pmatrix} 8 & & 8 & & 8 & & 8 & & 6 & 6 & 8 & & 8 \\ 13, 15, 15, 13, 15, 15, 13, 13, 15, 15, 17, 17, 15, 15, 15, 15, 15 \end{pmatrix}$

$\begin{matrix} 8 & 8 & 20, 20 \\ 15, 15, 15, 15, 15, 19, 19 \end{matrix}$ 3x [15, 16, 15, 15, 16, 15, 15, 16, 15, 16] $\begin{matrix} 20, 20 \\ 19, 19 \end{matrix}$

6x [17, 18, 17, 17, 18, 17, 17, 18, 17, 18] begin decelerating in the 4th repetition to *niente*.

Pause.

